

Mac's Portable Vertical Lift Technical Specifications

MODEL: PVL-50DC

SERIES: 750R

RATED LOAD: 750 lbs maximum

NUMBER OF PASSENGERS: 1 passenger with mobility equipment

DRIVE: AC Powered lift: 1/2 hp instant reverse motor, 115 VAC, 5.9 amp

OPTION: DC Powered lift: 1/2 hp motor, 12 VDC

INTERMEDIATE REDUCTION: V belt and pulley

FINAL DRIVE: #50 drive chain

MOTOR CONTROLLER: AC Powered lift: 24 VAC, 2 contactors; 1 up and 1 down

OPTION: DC Powered lift: 12 VDC, 2 contactors; 1 up and 1 down

STANDARD CONTROL: Constant pressure paddle control with key switch

SPEED: 10 feet per minute

LIFTING HEIGHT: Model PL-50 has a 50" maximum lifting height

PLATFORM SIZE: 36" x 48", straight thru platform (standard)

PLATFORM SPEC: Non-skid surgance & 12" auto folding ramp

MAIN FRAME CONSTRUCTION: Formed steel welded construction

CARRIAGE CONSTRUCTION: Steel tubing and formed channel welded construction

PLATFORM CONSTRUCTION: 1" steel tubing

AUTOMATIC LOWER RAMP: 12" automatic lowering ramp

MANUAL LOWERING DEVICE: Standard. Manual hand crank to raise and lower lift

FINISH: Weather resistant, exterior grade powder coat paint, sandblast and primer, rated for outdoor/indoor applications

Weather resistant/protected wires, controls and switches, rated for outdoor/indoor applications

LIMIT SWITCHES: Adjustable upper final limit switch

WEIGHT OF UNIT: Model PVL-50R: 450 lbs



Mac's Lift Gate Inc.
Tel: (800) 795-6227

2801 South Street Long Beach California 90805
www.macsliftgate.com

Mac's Portable Vertical Lift Technical Specifications

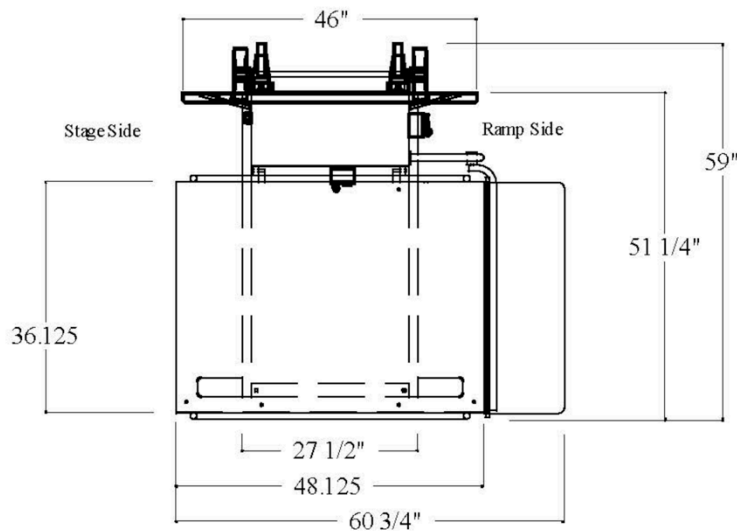
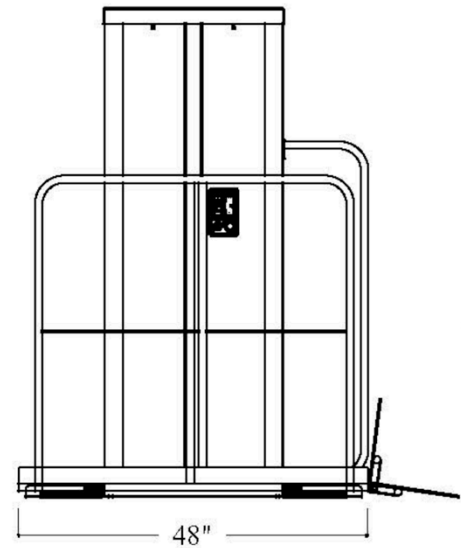
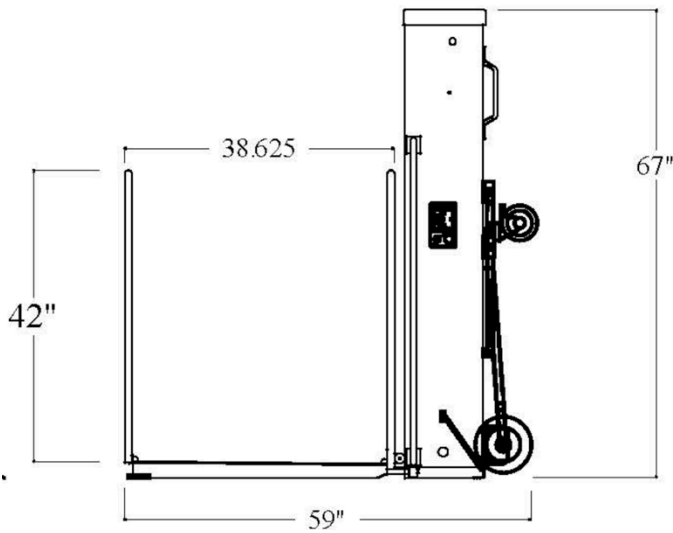
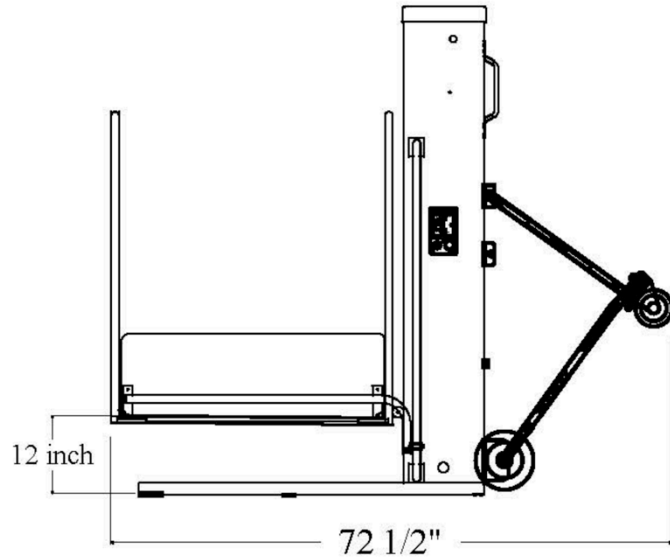
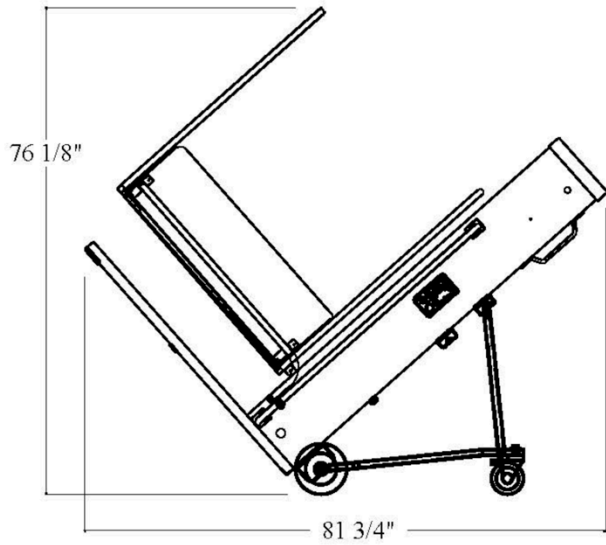

Mac's Lift Gate Inc.

2801 South Street

Long Beach California 90805

Tel: (800) 795-6227

www.macsliftgate.com

Mac's Portable Vertical Lift Technical Specifications



Mac's Lift Gate Inc.
Tel: (800) 795-6227

2801 South Street Long Beach California 90805
www.macsliftgate.com